



Meech
MEECH

Air Technology Air Efficiency Range

Effectively reducing
compressed air demand and costs



Contents:

Meech Air Technology 3

UK manufacturer of compressed air products that save energy, reduce noise levels and cool efficiently. Technical support is provided by our worldwide distributor network.

Compressed Air: The Facts 4

Squeezing the cost of compressed air – almost 90% of the UK manufacturing industry uses compressed air. Learn how Meech saves its clients thousands of pounds each year.

Sound Levels & Safety 5

Your safety - our first concern. Don't become a long term victim of high noise levels; many Meech products dramatically lower noise levels to improve the working environment.



Energy Saving Safety Nozzle 6-7

Energy Saving Safety Nozzles from Meech Air Technology can save up to 70% of compressed air demand whilst dramatically reducing noise levels.



Energy Saving Safety Blowgun 8-9

Energy Saving Safety Blowguns from Meech Air Technology combine an ergonomic lightweight gun handle with the Meech Nozzle. Meech Blowguns typically save up to 70% of compressed air usage and reduce noise levels.



High Thrust Jet 10-11

Meech Air Technology High Thrust Jets are designed to provide a high power blast of air whilst reducing compressor demand and lowering noise levels.



Air Amplifier/Mover 12-13

Meech Air Technology Air Amplifiers provide large airflows whilst consuming a minimal volume of compressed air. The Air Amplifiers are available in three sizes and in either aluminium or stainless steel.



Air Curtain/Knife 14-15

The Air Curtain from Meech Air Technology provides an efficient blade of air for wide area blow-off and drying applications. The Air Curtain offers compressed air savings of up to 70%.

NOTE:

- Actual results may not reflect figures published here.
- All Meech products are tested at factory settings.



We've got the world covered

Wherever you are in the world, you'll find Meech hard at work, providing a wide range of businesses with technical expertise. From our headquarters and Technical Centre in the UK, our manufacturing subsidiary in the USA and sales offices in Belgium, Hungary and China, we've got the world covered.

In fact, our distribution network now covers over 50 countries, providing easy access to fully trained, carefully selected Meech distributors, who can provide in-depth support - wherever you are based.

All our distributors are specialist in compressed air and fully conversant with the application, operation and installation of Meech Air Technology products. This allows them to evaluate the best solution for each particular situation and understand how it will be integrated into the production environment.

Outstanding quality as standard

As with every Meech system, quality is at the heart of all air technology products. We always work to the highest possible quality standards in everything we do: manufacturing, customer support and technical know-how. Our quality management system is certified by BSI to ISO9001. Products manufactured by Meech are appropriately certified to international standards. They carry markings including CE and UL/CSA (CUL).

We also hold ATEX and UL "EX" approvals for use in hazardous environments. So, you can be sure you've chosen a solution and a company that will meet your own exacting standards.

World leaders in web cleaning and static control

No-one knows the specialist fields of web cleaning and static control better than Meech and the practical benefits can be seen at work. Unique design characteristics in each of our web cleaning systems, whether it is contact or non-contact, will help you to maximise the return on your investment.

All the experience you need

Established in 1907, Meech has earned a worldwide reputation for the design and manufacture of effective, durable systems that are supported by our knowledgeable technical team. With so much to offer, no wonder our global user list has grown to in excess of 7,000 companies.

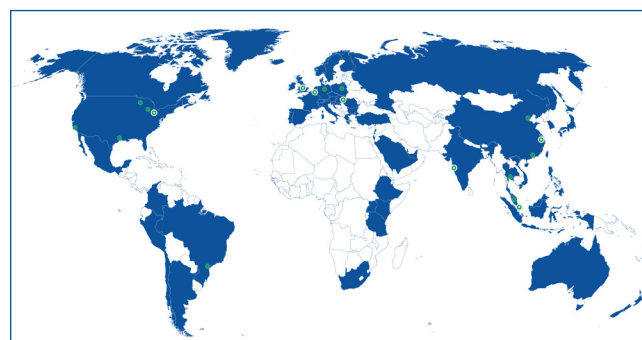

Compressed Air: The Facts

Referred to as the fourth utility, compressed air is seen as an essential resource in virtually every industrial sector. Used in industries as varied as food and drink to oil and gas, it's a versatile and reliable way of transmitting energy. Compressed air is so popular it's now used in over 90% of all manufacturing and accounts for approximately 10% of all electricity supplied to industry.

However, how much do companies and employees actually know about compressed air?

Typically, in any system over 30% of compressed air is lost through air leaks and much more is wasted through misuse, poor maintenance and lack of investment.

There are many reasons why companies should take an interest in their compressed air. Efficient well run compressed air systems provide many benefits, that include;

- Energy/environmental saving
- Cost saving
- Added reliability
- Added performance
- More efficient operation
- Eliminates waste
- Extends life of compressor

Good working practice stipulates that all compressed air systems should be maintained and reviewed regularly.

Meech recommend that compressed air audits and leak surveys should be part and parcel of any company's plans, but we also want to take this further, by reducing the total volume of compressed air used at the point of application. As can be seen in the chart below, on average 73% of a compressor's cost is spent producing compressed air. By reducing this percentage you can make significant savings both environmentally and financially.

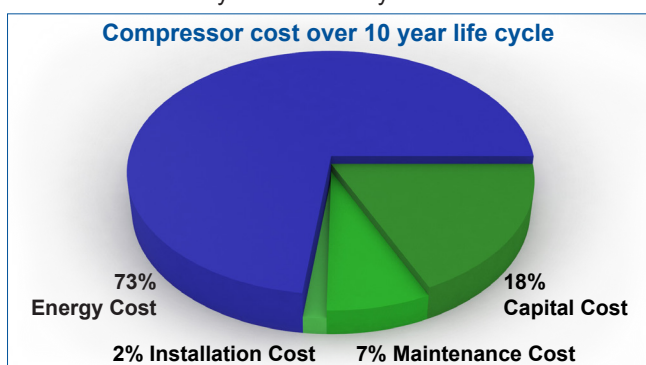

Meech Air Technology

The Meech Air Technology (MAT) range is designed to reduce energy costs by entraining ambient air into the compressed air flow resulting in the use of less compressed air to achieve the same results.

To give one example; installation of 1 x Meech Energy Saving Nozzle on a pre-existing 8mm open pipe immediately reduces the compressed air consumption, by a massive 77%, which could equal a saving of up to £3,000 per year.

When this one nozzle is multiplied over a whole factory the savings can run into many thousands. Furthermore the MAT range is inexpensive, easy to install and requires practically no maintenance.

How it Works

The Energy Saving products work using a naturally occurring phenomenon called the Coanda Effect. This is described as a tendency for a fluid jet to be attracted to a nearby surface.

The Coanda Effect was discovered by Henri-Marie Coanda in 1930, he observed that a stream of air (or any fluid) emerging from a nozzle tends to follow a nearby curved surface, if the curvature of that surface or angle is not too sharp.

Meech utilises the Coanda effect by blowing high velocity compressed air over a curved surface. This creates an area of low pressure that entrains the ambient air at ratios of up to 25:1

This entrainment allows the input air pressure to be lowered without affecting the air velocity or volume. In some cases compressed air demand can be cut by up to 70% saving both energy and costs.

Tested and built to last

MAT products are manufactured to be easy and quick to install, as well as hardwearing. There are no moving parts in any of the MAT products, which reduces maintenance and means there is practically nothing to go wrong.

Every product is tested on our specially designed Compressed Air Bench. We measure flow rates, air consumption and air pressures of all our products before they are shipped.

Health and Safety

MAT products are safe for your workforce. Compressed air is a powerful source of energy and just because you can't see it doesn't mean it can't harm you. We ensure that all our products are designed and manufactured to the highest standard, preventing any injury to end users.

There are many risks with compressed air and care should always be taken when using it. One of the most serious dangers is compressed air being blown under the skin via an open wound. This can lead to an air embolism which in extreme cases can be fatal.

One example of this is "dead-ending". This occurs when an open air outlet or other aperture is blocked. If this blockage is caused by a body part there is a risk of an air embolism. Meech products are all designed to dead-ending, the unique design means the air outlet cannot be blocked which reduces any risk.

Noise: A Health Hazard

Loud noise at work can damage your hearing and in the manufacturing environment noise is usually generated by machinery tools and compressed air.

DBA is the unit of measurement of how loud a noise source is, ranging on a comparative scale from 0-194. A dBA reading of "0" indicates the faintest sound the human ear can detect, while a dBA reading of "180" would be the equivalent to standing on a rocket pad during launch.

Reducing compressed air by just a few decibels can make a big difference. The decibel scale is algorithmic, not linear, so, a reduction of 3 decibels gives a 50% reduction in sound pressure.

So, in real terms what may seem like a small drop of 3 decibels actually makes a huge difference to the audible sound level.

The UK health and safety executive has a level of noise exposure that may not be exceeded, these values are:

	Daily/Weekly Exposure (dBA)	Peak Sound Pressure (dBA)
Lower exposure value (average level)	80	135
Upper exposure value (average level)	85	137
Exposure limit value (maximum level)	87	140

All MAT products are designed with noise in mind and all offer significant reductions when compared to standard compressed air open pipes.

As the chart below shows, a standard 6mm compressed air pipe has a noise level of approximately 90dBA. The Meech safety nozzle is only 79dBA (when running at 80psi). A massive 11dBA drop reproduced throughout the MAT range.

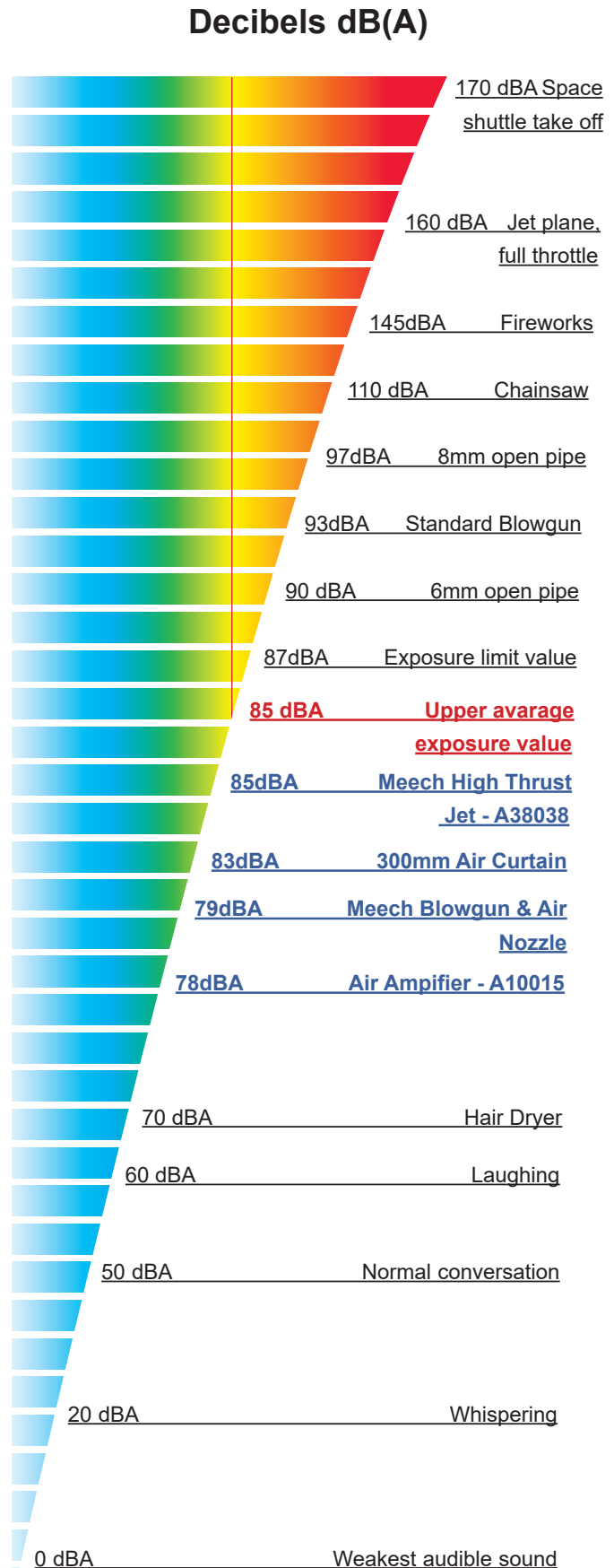

*Meech products measured at 80psi (5.4 Bar)

Energy Saving Safety Nozzle



The Energy Saving Safety Nozzles from Meech directs compressed air over a curved surface, this action entrains ambient air and amplifies the total air flow. Meech Nozzles can save up to 70% of compressed air demand and significantly reduce noise levels. Energy Saving Safety Nozzles have hundreds of applications that will significantly reduce compressed demand and running costs.

How they work

Compressed air is released through an adjustable annular slot at the base of the nozzle cone. The compressed air flows at high velocity over the outside of the cone. This high velocity air flow entrains the surrounding ambient air at a ratio of 25:1. As a result the total air flow exiting the nozzle is increased. This means both the air pressure and air consumption can be reduced.

Features and Benefits

- Energy Saving – Air Nozzles can cut compressed air demand by up to 70% and reduce running costs.
- Noise Reduction – Up to 30 dBA noise reduction.
- Innovative design – offers Air Amplification at a ratio of 25:1.
- No moving parts – Virtually no maintenance.
- Health and Safety compliant – Nozzle design prevents dead-ending.
- Easy to install – Available with either a 1/8" or 1/4" BSP fitting.
- Adjustable – Allows for application specific set-up.
- Aluminium or Stainless Steel – Can be used in most environments.
- Excellent performance - Thrust levels in excess of 250 grams, whilst air consumption is only 15cfm (425l/min)

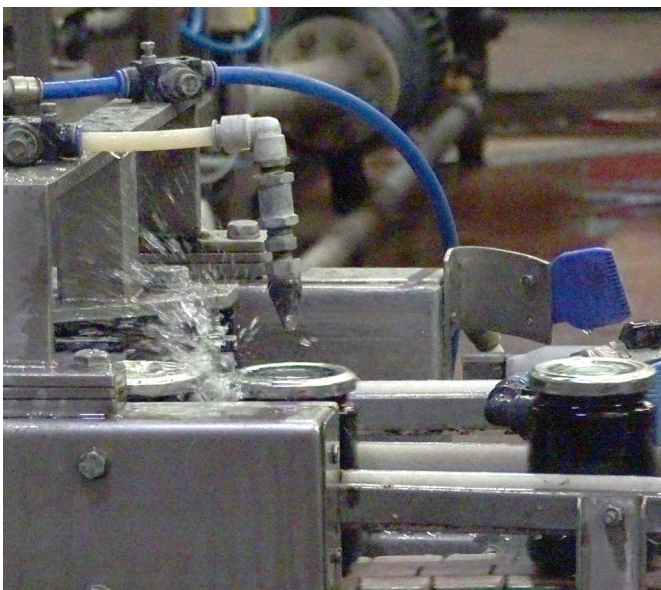
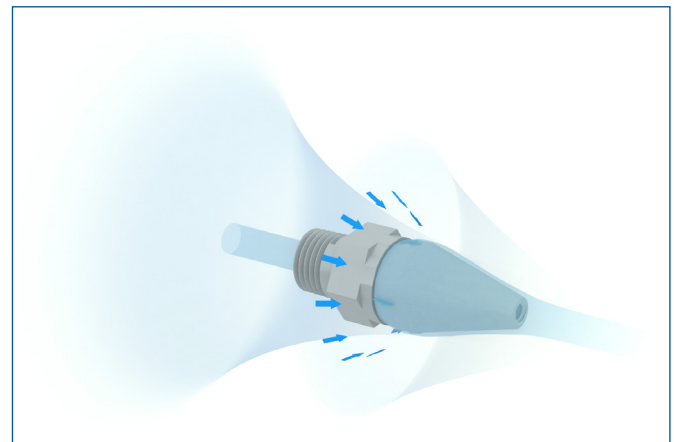

Nozzle being used to dry jars before being date stamped

Applications

- **Replacement of Open Pipes**
Meech Nozzles can be fitted to virtually any existing open pipe
- **Product cleaning/Swarf removal**
The 25:1 air amplification makes the Nozzles ideal for blow cleaning machinery or components.
- **Part Ejection**
Meech Nozzles can be used to remove items from a conveyor line or, in conjunction with a solenoid, to remove selected items from a production run.
- **Liquid Blow off**
The column of air can be used to blow liquid from a product or component
- **Product Pushing**
Meech Nozzles can be used on a production line to assist with conveying – for example a Meech nozzle will effectively help to push cans.

Dimensions

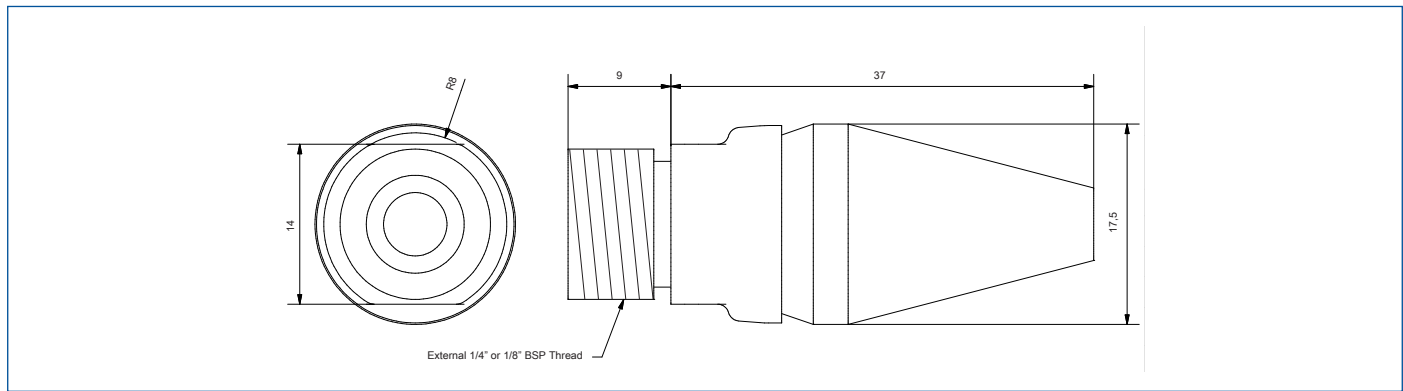

Energy Saving Example - Nozzle

Company A use 5 x 6mm ID open air pipes running at 80psi (5.4 Bar) inlet air pressure. The open pipes are used to move items along a production line. They are running constantly for 16 hours a day, 5 days a week, and 48 weeks a year. Company A has electricity costs of 8p per kW/hr.

Each open air pipe has an air consumption of 34 cfm (963 l/min) giving a total air consumption of 170cfm (4,814 l/min). Each of the open pipes has a noise level of 90 dBA.

By fitting 5 x Meech Energy Saving Safety Nozzles to the existing 6mm pipe a dramatic reduction can be seen in both air consumption and noise level.

When running at 80psi (5.4 Bar) each Nozzle has an air consumption of 15cfm, giving a total air consumption of 75cfm (2,125 l/min). Each Nozzle has a noise level of 79

dBA, a drop of 11 dBA per Nozzle when compared to the 6mm open pipe.

This shows a massive 95cfm (2,690 l/min) saving in compressed air or an overall saving of 56% in air consumption. Equally running costs are also reduced from £9,792 per year to £4,320 per year, which is a saving of £5,472 per year. Finally, the low cost of the Energy Saving Air Nozzles means the payback period could be as little as 2 days.

Running Cost Comparison

Duration	1x Energy Saving Nozzle (£)	1x 6mm Open Pipes (£)	5x Energy Saving Nozzle (£)	5x 6mm Open Pipes (£)
Per Day	3.60	8.16	18.00	40.80
Per Week	18.00	40.80	90.00	204
Per Year	864	1,958	4,320	9,792

Technical Information

Product Code	Product	Total Weight (grams)	Air Amplification	Thread Type	Factory Setting*
A48009	Aluminium Nozzle	16.2	25:1	1/8" BSP Male or 1/4" BSP Male	15 cfm (425 l/min)
A40009	Stainless Steel Nozzle	45.0			

Note: Nozzles are sold in bags of 5

*Factory set to – 80psi to use 15 cfm (425 l/min) of air

Air Consumption and Noise Comparison

Inlet Air Pressure	Air Consumption										Sound Level*				
	cfm					l/min					dBA				
psi	20	40	60	80	100	20	40	60	80	100	20	40	60	80	100
Bar	1.4	2.7	4.1	5.4	6.8	1.4	2.7	4.1	5.4	6.8	1.4	2.7	4.1	5.4	6.8
All Meech Nozzles	5	9	12	15	18	142	255	340	425	510	65	71	76	79	81
Ø6mm Pipe	11	17	27	34	40	311	481	765	963	1133	70	80	87	90	95
Ø8mm Pipe	26	40	60	75	82	736	1133	1699	2124	2322	77	88	95	97	98

* Sound level taken 1m from target
Measured at factory setting

Energy Saving Safety Blowgun



Features and Benefits

- Energy Saving Safety Blowguns can cut compressed air demand by up to 70% and reduce running costs.
- Noise Reduction – Up to 30 dBA noise reduction compared to standard blowgun.
- Innovative design – offers Air Amplification at a ratio of 25:1.
- No moving parts – Virtually no maintenance.
- Health and safety compliant – Nozzle design prevents dead-ending.
- Hard-wearing – Aluminium gun handle.
- Adjustable – Allows for application specific set up.
- Available with either Aluminium or Stainless Steel Nozzle – Can be used in most environments.
- Excellent performance - Thrust levels in excess of 250 grams, whilst air consumption is only 15cfm (425l/min)

The Energy Saving Safety Blowgun from Meech combines an ergonomic lightweight gun handle with the Meech Energy Saving Safety Nozzle. A Meech Blowgun can save up to 70% of compressed air demand and significantly reducing noise levels. The Blowgun handle is manufactured from aluminium making it more hard-wearing than a standard plastic blowgun.

How they work

Compressed air is released through an adjustable annular slot at the base of the nozzle cone. The compressed air flows at high velocity over the outside of the cone. This high velocity air flow entrains the surrounding ambient air at a ratio of 25:1. As a result the total air flow exiting the nozzle is increased. This means both the air pressure and air consumption can be reduced.

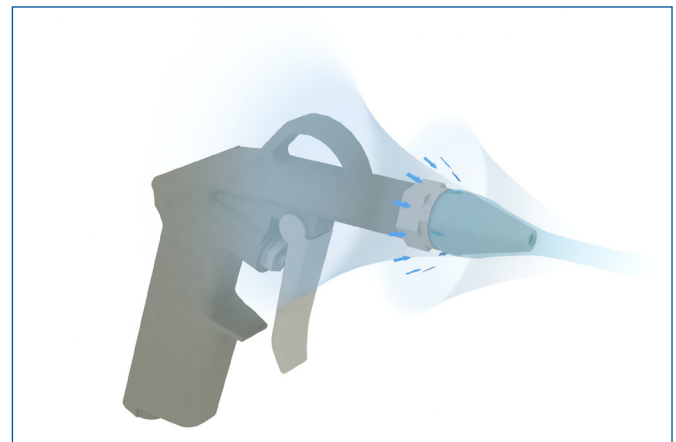

Blowgun used to blow swarf from work station.

Applications

- **Replace Standard Blow Guns**
Meech Blowguns can replace an existing standard Blowgun. They offer both cost and energy savings, in addition they are hard-wearing, so will not need to be replaced as often.
- **Product cleaning/Swarf removal**
The 25:1 air amplification makes the Blowgun ideal for blow cleaning machinery or components.
- **Liquid Blow off**
The Blowgun can be used to blow off liquid from a product or component.

Dimensions

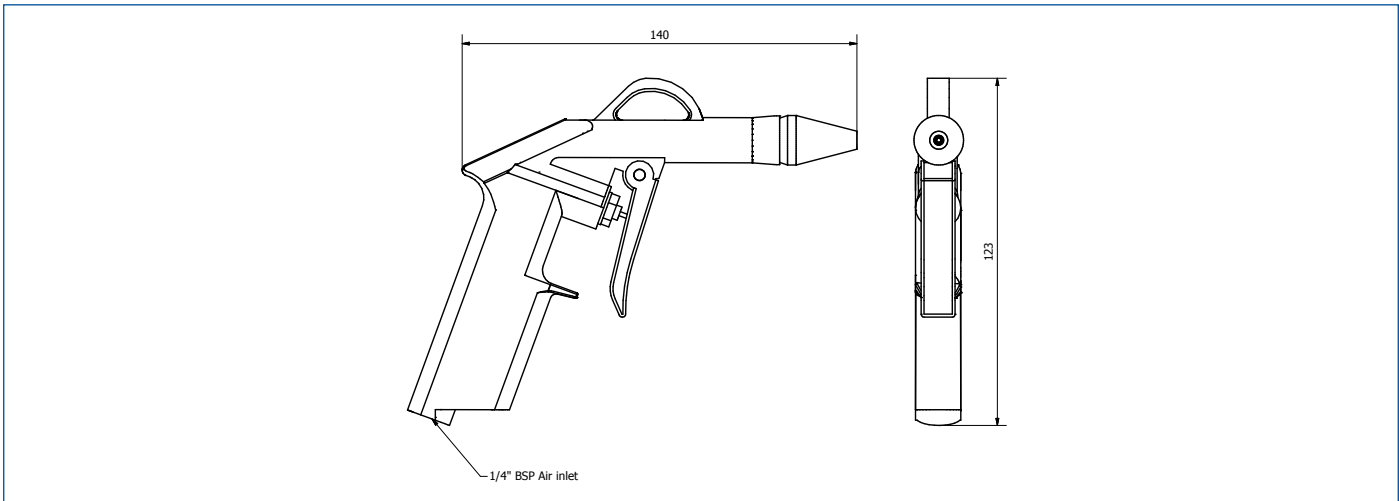

Energy Saving Example – Blowgun

Company “B” uses 50 standard blowguns to blow Swarf from machined parts, the blowguns are running at an inlet air pressure of 80psi. It takes approximately 1 minute to clean each part and each operator cleans 450 parts per day. Company “B” works 5 days a week, 48 weeks per year and has an electricity cost of 8p per kW/hr.

Each standard blowgun consumes 22cfm (623 l/min) and costs £2.48 per day to run. Giving a total air consumption of 1,100 cfm (31,148 l/min) and a total cost of £123.00 per day.

Company “B” will significantly reduce both air consumption and costs by switching to Meech Energy Saving Safety Blowguns. When running at 80psi Meech Blowguns will consume 15cfm (425 l/min) and cost £1.69 per day to run. Giving a total air consumption of 750cfm (21,237 l/min) and a total cost of £84.38 per day.

As shown in the table below this adds up to a yearly saving of over £12,000.

Further to this, investment in 50 x Meech Blowguns will cost under £1,000.

The noise level will be reduced from 93dBA to 79dBA and finally the Meech aluminium gun handles will be more hard-wearing than the standard plastic versions.

Running Cost Comparison

Duration	1 x Meech Blowgun (£)	1 x Standard Blowgun (£)	50 x Meech Blowguns (£)	50 x Standard Blowguns (£)
Per Day	1.69	2.48	84.38	124
Per Week	8.44	12.38	422	619
Per Year	405	594	20,250	29,700

Technical Information

Product Code	Product	Total Weight (grams)	Air Amplification	Factory Setting*
A45400	Blowgun with Aluminum Nozzle	136	25:1	15 cfm (425 l/min)
A45400SS	Blowgun with Stainless Steel Nozzle	168	25:1	15 cfm (425 l/min)

*Factory set to – 80psi to use 15 cfm (425 l/min) of air

Air Consumption and Noise Comparison

Inlet Air Pressure	Air Consumption										Sound Level*				
	cfm					l/min					dBA				
psi	20	40	60	80	100	20	40	60	80	100	20	40	60	80	100
Bar	1.4	2.7	4.1	5.4	6.8	1.4	2.7	4.1	5.4	6.8	1.4	2.7	4.1	5.4	6.8
Meech Blowguns	5	9	12	15	18	142	255	340	425	510	65	71	76	79	81
Standard Blowgun	9	14	18	22	29	255	396	510	623	821	75	83	90	93	95

* Sound level taken 1 meter from source
Measured at factory setting

Energy Saving High Thrust Jet



Meech Energy Saving High Thrust Jets provide large airflows whilst consuming a minimal volume of compressed air. High Thrust Jets are perfect for providing short powerful bursts of air.

How they work

High Thrust Jets use a small amount of compressed air to generate a high powered, blast of air. Compressed air is released through an adjustable circular slot inside the High Thrust Jet. This creates a 'tube of air' that travels on the inside of the Jet towards the front. The air movement creates areas of low pressure which entrains ambient air at ratios of between 4 and 6:1.

Features and Benefits

- Energy Saving – High Thrust Jets can cut compressed air demand by up to 70% and reduce running costs.
- Noise Reduction – Up to 30 dBA noise reduction compared to an open pipe.
- Innovative design – offers Air Amplification at a ratio of between 4 and 6:1.
- No moving parts – No maintenance.
- Easy to install – The standard BSP thread will connect to most existing air supplies.
- Adjustable – Allows for application specific set up.
- Versatile – 4 different sizes makes them suitable for a wide variety of applications.
- Excellent performance - Thrust levels in excess of 450 grams, whilst air consumption is only 26cfm (736l/min)

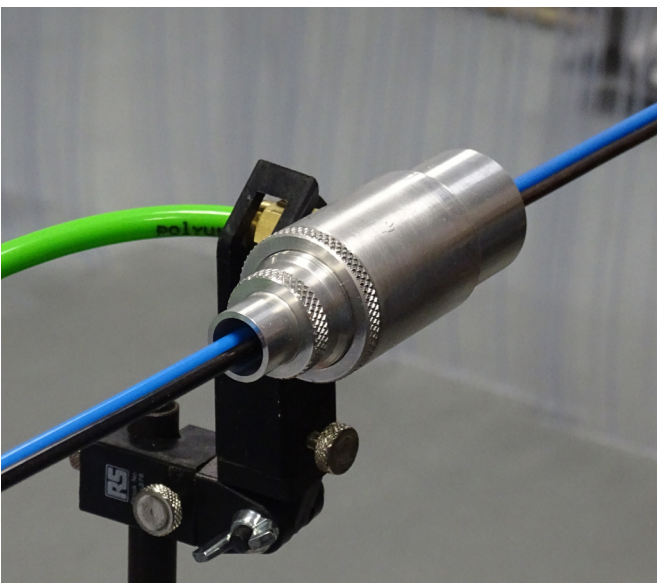
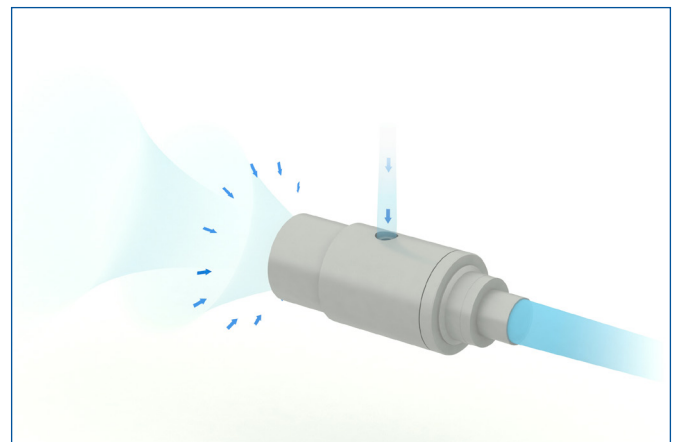

High Thrust Jet used to cool plastic tube

Applications

- **Product redirection**
The high powered blast of air makes the High Thrust Jet perfect for ejecting product from a production line. Typically used in the Food and Drink industry to remove substandard items.
- **Product Drying**
The High Thrust Jets produced a high velocity concentrated tube of air. Effective drying can be achieved by passing material through the middle of the High Thrust Jet.
- **Product Cooling**
The high velocity air flow means High Thrust Jets can be used to cool products or components. The small size allows them to be used in confined spaces.
- **Product redirection**
High Thrust Jets can be used to move products along a production line.

Dimensions

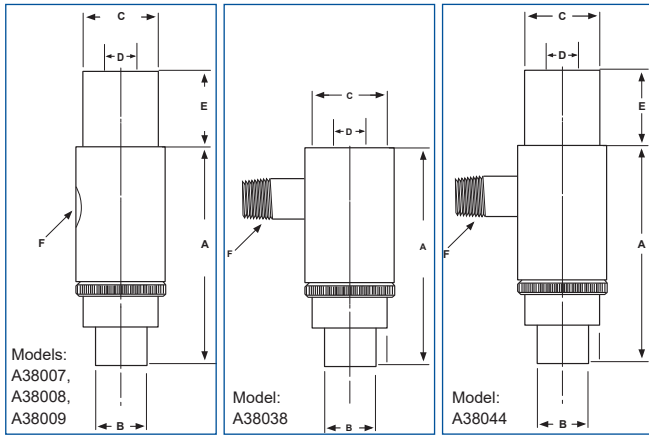

	A38007	A38038	A38044	A38008	A38009
A	39	55	74	71	147
B	9	13	13	17	34
C	16	25	22	32	66
D	6	9.5	9.5	12	25
E	12	N/A	19	24	50
F	M5x 6mm	1/8" BSP	1/8" BSP	1/8" BSP	1/8" BSP

Energy Saving Example - High Thrust Jet

Company D uses 8 x 8mm ID open air pipes, running at 80psi (5.4 Bar), on 4 production lines. They are used to blow underweight packages of baked confectionary from the production line into a reject bin. On average the open pipes run for 15 minutes every hour and are running for 8 hours a day, 6 days a week and 48 weeks a year. Company C has electricity costs of 8p per kW/hr.

The air consumption of each 8mm open pipe is 75cfm (2,124 l/min) making a total air consumption of 600cfm (16,990 l/min) at 80psi (5.4 Bar). In financial terms these 8 pipes will cost over £5,000 per year to run.

By replacing the open pipes with 8 x Meech High Thrust Jets (A38038) the company can significantly reduce the air consumption and save money.

8 x Meech Energy Saving High Thrust Jets use 26 cfm each at 80 psi (5.4 Bar), making a total air consumption of 208cfm (5,890 l/min). In total the cost of running the 8 x High Thrust Jets is £1,797 per year.

Comparing the two methods the High Thrust Jets will save approximately £3,387 per year. The High Thrust Jets will also be quieter to run than the 8mm open pipe.

Running Cost Comparison

Duration	1 x High Thrust Jet (£)	1 x 8mm Open Pipe (£)	8 x High Thrust Jet (£)	8 x 8mm Open Pipe (£)
Per Day	0.78	2.25	6.24	18.00
Per Week	4.68	13.50	37.44	108
Per Year	224	648	1,797	5,184

Technical Information

Product Code	Product	Air Amplification	Thread Type	Total Weight (grams)	Factory setting @ 80psi (5.4 bar)
A38007	9mm Aluminium	4:1	m5 x 6mm	19	10 cfm (283 l/min)
A38038	13mm Stainless Steel	4:1	1/8" bsp (male)	128	26 cfm (736 l/min)
A38044	13mm Stainless Steel Inline	4:1	1/8" bsp (male)	140	26 cfm (736 l/min)
A38008	17mm Aluminium	6:1	1/8" bsp	123	13 cfm (368 l/min)
A38009	34mm Aluminium	12:1	1/8" bsp	980	23 cfm (651 l/min)

Air Consumption and Noise Comparison

Inlet Air Pressure	Air Consumption										Sound Level*				
	cfm					l/min					dBA				
psi	20	40	60	80	100	20	40	60	80	100	20	40	60	80	100
Bar	1.4	2.7	4.1	5.4	6.8	1.4	2.7	4.1	5.4	6.8	1.4	2.7	4.1	5.4	6.8
A38007	3	5	8	10	11	85	142	227	283	311	72	79	82	87	90
A38038	13	18	22	26	29	368	510	623	736	821	75	80	83	85	89
A38044	13	18	22	26	29	368	510	623	736	821	75	80	83	85	89
A38008	4	8	10	13	15	113	227	283	368	425	65	73	77	80	82
A38009	14	24	34	43	50	396	680	963	1218	1416	76	81	84	86	90
6mm Pipe	11	17	27	34	40	311	481	765	963	1133	70	80	87	90	95
8mm Pipe	26	40	60	75	82	736	1133	1699	2124	2322	77	88	95	97	98

* Sound level taken 1 meter from source
Measured at factory setting

Energy Saving Air Amplifier



Meech Energy Saving Air Amplifiers provide large airflows whilst consuming a minimal volume of compressed air. Available in 5 sizes, with outlets ranging from 18 to 100mm Air Amplifiers are a versatile and energy efficient way of utilising compressed air.

How they work

A tiny amount of compressed air is released through an adjustable circular slot inside the Air Amplifier. This creates a 'tube of air' that travels on the inside of the Amplifier towards the front. The air movement creates areas of low pressure which entrains ambient air at ratios of between 4 and 25:1 (model dependent).

Features and Benefits

- Energy Saving – Air Amplifiers can cut compressed air demand by up to 70% and reduce running costs.
- Noise Reduction – Up to 30 dBA noise reduction compared to an open pipe.
- Innovative design – offers Air Amplification at a ratio of between 4 and 25:1.
- No moving parts – Virtually no maintenance.
- Easy to install – Standard fitting will connect to most existing air supplies.
- Reduce demand on Compressor – Air Amplifiers will reduce compressed air usage.
- Adjustable – Allows for application specific set up.
- Available in Aluminium and Stainless Steel – can be used in most environments.
- Versatile – 5 different sizes makes them suitable for a wide variety of applications.
- Excellent performance - Thrust levels in excess of 450 grams, whilst air consumption is only 26cfm (736l/min)

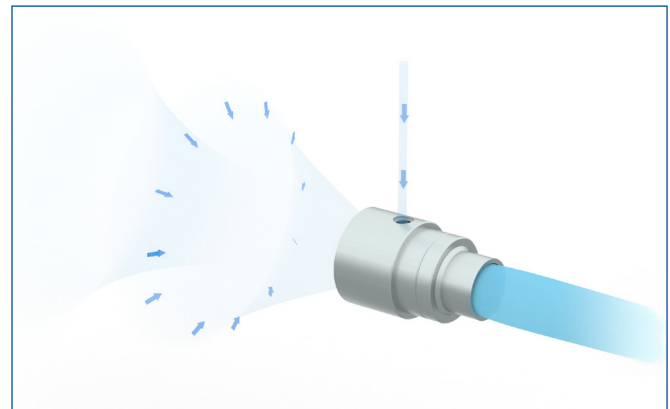

Applications

- **Product Redirection**
The wide spread of air exiting the Air Amplifier makes them ideal for moving products or components along a conveyor or production line.
- **Blowing and Sucking**
The unique design allows an Air Amplifier to suck and blow air. This means they can be used to either blow particles away or vacuum material up.
- **Product Drying**
The high velocity air flow means Air Amplifiers can be used to dry products or components.
- **Product Cooling**
The high velocity air flow means Air Amplifiers can be used to cool products or components.
- **Product Ejection**
When used in conjunction with a Solenoid Valve Air Amplifiers can be used to blow 'reject' products or components from production line.

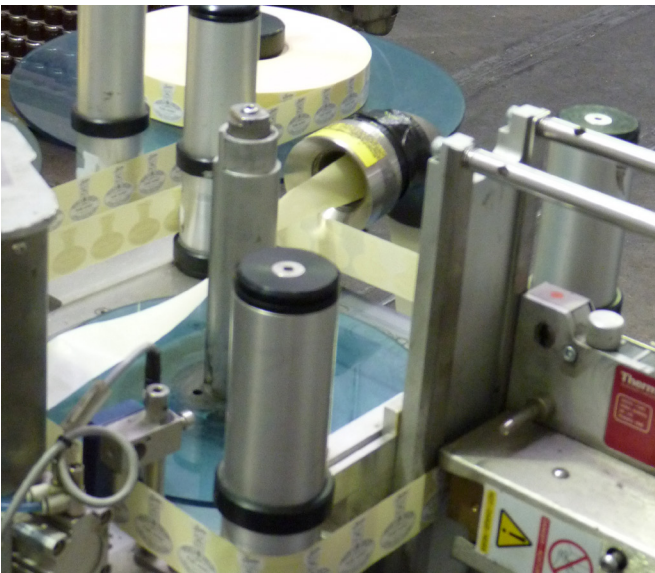

Air Amplifier used to remove the liner away from production line.

Dimensions

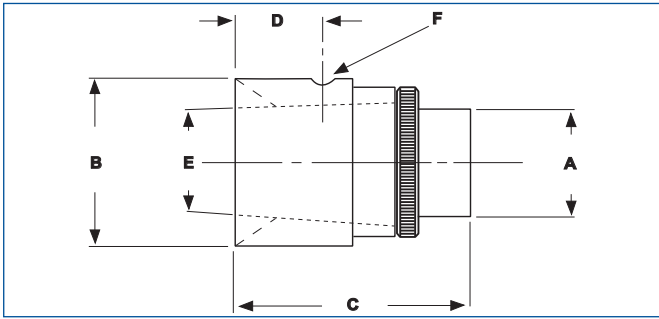

	A15005	A15008/ A10008	A15006	A15015/ A10015	A15030/ A10030
A	18	32	37	51	100
B	29	50	60	76	127
C	44	73	90	83	128
D	13	26	30	27	38
E	12	20	25	40	74
F	M5 x 6mm	¼" BSP	¼" BSP	⅜" BSP	½" BSP

Energy Saving Example - Air Amplifier

Company C uses 4 x 8mm ID open air pipes running at 80psi (5.4 Bar) to blow swarf from a component as it travels along a production line. The open pipes run constantly for 6 hours a day, 5 days a week and 48 weeks a year. Company C has electricity costs of 8p per kW/hr.

The air consumption of 1 x open 8mm pipe is 75cfm (2,124 l/min) making a total air consumption of 225cfm (6,371 l/min) at 80psi (5.4 Bar).

By replacing the open pipes with 4 x Meech Air Amplifiers (A15015) the company can significantly reduce the air consumption and save money. The Air Amplifiers will also improve cleaning results.

4 x Meech Energy Saving Air Amplifiers use 25 cfm each at 80 psi (5.4 Bar), making a total air consumption of 100cfm (2,832 l/min). The added air spread will also provide an improved cleaning performance.

The table below highlights the saving that can be achieved by replacing the 4 x open compressed air pipes with 4 x Air Amplifiers

Running Cost Comparison

Duration	1 x 12mm Air Amp (£)	4 x 12mm Air Amp (£)	1 x 8mm open pipe (£)	4 x 8mm open pipe (£)
Per Day	2.34	9.36	4.50	18.00
Per Week	14.04	56.16	27.00	108.00
Per Year	673.92	2,695	1,296	5,184

Technical Information

Product Code	Product	Air Amplification	Thread Type	Total Weight (grams)	Factory setting @ 80psi (5.4 bar)
A15005	18mm Aluminium Air Amplifier	4:1	M5 x 6mm	35	13cfm (368 l/min)
A15008/A10008	32mm Aluminium / Stainless Steel Air Amplifier	12:1	¼" BSPP	176(A) / 517(SS)	15cfm (425 l/min)
A15006	37mm Aluminium Air Amplifier	12:1	G1 x 6mm	312	23cfm (651 l/min)
A15015/A10015	51mm Aluminium / Stainless Steel Air Amplifier	20:1	⅜" BSPP	372(A) / 1,081(SS)	25cfm (708 l/min)
A15030/A10030	100mm Aluminium / Stainless Steel Air Amplifier	25:1	½" BSPP	1,253(A) / 3,700(SS)	30cfm (850 l/min)

Air Consumption and Noise Comparison

Inlet Air Pressure	Air Consumption										Sound Level*				
	cfm					l/min					dBA				
psi	20	40	60	80	100	20	40	60	80	100	20	40	60	80	100
Bar	1.4	2.7	4.1	5.4	6.8	1.4	2.7	4.1	5.4	6.8	1.4	2.7	4.1	5.4	6.8
A15005	4	8	10	13	15	113	227	283	368	425	70	75	82	83	86
A15008/A10008	8	11	13	15	17	227	311	368	425	481	59	73	76	79	83
A15006	9	14	19	23	27	255	396	538	651	765	66	77	82	83	86
A15015/A10015	13	18	22	25	28	368	510	623	708	793	59	69	75	78	83
A15030/A10030	15	21	26	30	34	425	595	736	850	963	59	68	73	75	78
6mm Pipe	11	17	27	34	40	311	481	765	963	1133	70	80	87	90	95
8mm Pipe	26	40	60	75	82	736	1133	1699	2124	2322	77	88	95	97	98

* Sound level taken 1 meter from source
Measured at factory setting

Energy Saving Air Curtain

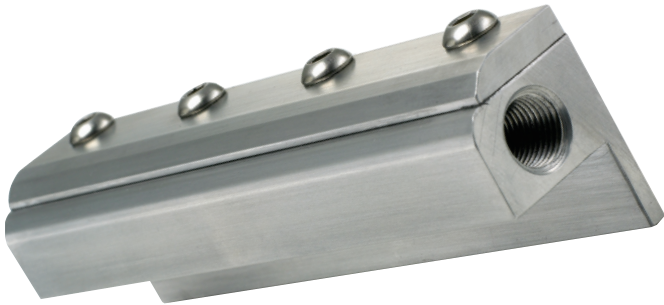

Meech Energy Saving Air Curtain provides an efficient laminar sheet of air for wide area cleaning and drying applications. Meech Air Curtains are the perfect replacements for drilled or slotted lengths of pipe. In addition, the Air Curtain offers up to 70% compressed air savings when compared to the drilled pipes.

Features and Benefits

- Energy Saving – Air Curtains can cut compressed air demand by up to 70% and reduce running costs.
- Noise Reduction – Up to 30 dBA noise reduction compared to a drilled pipe.
- Innovative design – offers Air Amplification at a ratio of 25:1.
- No moving parts – No maintenance.
- Easy to install – The flange running the entire length can be drilled at any position, allowing for easy installation.
- Available in any length – Can be manufactured in any length between 50 and 2,500mm.

How they work

The Air Curtain releases a small volume of compressed air through a .002" (.0508mm) slot along its entire length. The 'blade' of air travels down the front face of the Air Curtain creating an area of low pressure behind it that entrains ambient air at a ratio of up to 25:1, delivering a massive airflow to the target.



Air Curtains used to dry top of jars

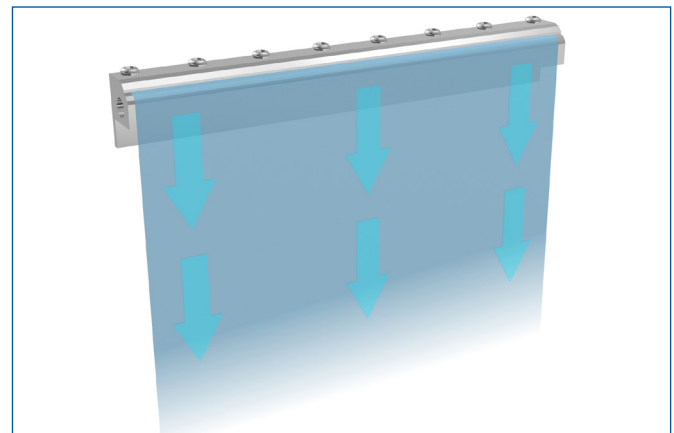

Applications

- **Product Drying** - The laminar sheet of air that is created by the Air Curtain is perfect for the drying of a wide variety of components.
- **Product Cooling** - The 25:1 air amplification makes the Air Curtain ideal for any type of cooling.
- **Product cleaning/Swarf removal** - The unique design of the Air Curtain allows it to clean over wide areas.
- **Air Barrier** - Air Curtains can be used to form an air barrier. For example Air Curtains have been used above oven doors to keep heat within the oven.

Dimensions

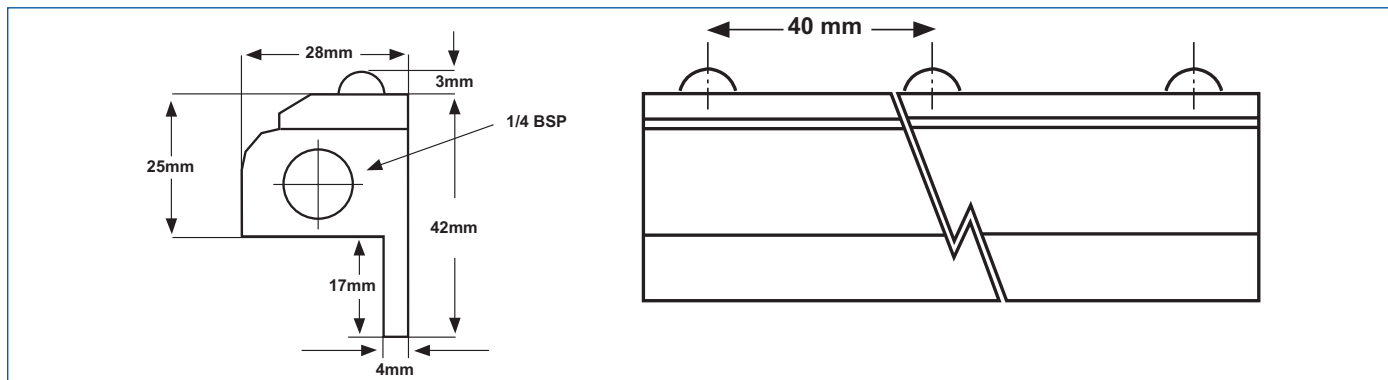

Energy Saving Example - Air Curtain

Company 'E' uses a drilled 300mm pipe with 11 x 2mm holes drilled along its length at 25mm intervals. The pipe is used to blow swarf from routed MDF panels. The homemade length of pipe runs constantly for 15 hours a day, 6 days a week and 48 weeks a year. The electricity costs for company 'E' is 8p per kW/hr.

The 300mm pipe has an air consumption of 58cfm (1,642 l/min) at 80 psi (5.4 Bar). The thrust level from the 300mm pipe at this pressure will be approximately 470 grams. The total compressed air cost of the 300mm pipe adds up to £3,758 per year.

By replacing the 300mm pipe with a 300mm Meech Air Curtain, Company 'E' will see both cost and environmental savings, as well as an improved cleaning performance.

A Meech 300mm Energy Saving Air Curtain running at 80 psi (5.4 Bar) will consume 30 cfm (849 l/min) and have a thrust level of 834 grams. The added thrust from the Meech Air

Curtain means Company E can reduce the inlet air pressure to achieve the same results.

Company 'E' was able to reduce the air pressure from 80 psi (5.4 Bar) to 40 psi (2.7 Bar) and still get over 400 grams of thrust. This decrease in inlet air pressure has reduced the consumption from 52 cfm (1,472 l/min) to 30 cfm (849 l/min). The total cost of a Meech 300mm Air Curtain running at 40 psi (2.7 bar) is £1,944.

This adds up to an annual saving of £1,816. Finally, the cleaning performance will also improve. The laminar sheet of air, running the entire length of the Air Curtain cleans better than the 'striped' cleaning effect produced by the drilled pipe.

Running Cost Comparison

Duration	300mm Air Curtain (£)	300mm Drilled Pipe (£)
Per Day	6.75	13.05
Per Week	40.50	78.30
Per Year	1,944	3,758

Air Consumption and Noise Comparison

Product Code	Product	Air Consumption										Sound Level*					Thrust Level*				
		cfm					l/min					dBA					grams				
psi		20	40	60	80	100	20	40	60	80	100	20	40	60	80	100	20	40	60	80	100
Bar		1.4	2.7	4.1	5.4	6.8	1.4	2.7	4.1	5.4	6.8	1.4	2.7	4.1	5.4	6.8	1.4	2.7	4.1	5.4	6.8
A85003	80mm Air Curtain	5	8	11	14	17	142	227	311	396	481	64	73	79	82	84	51	110	192	286	350
A85006	150mm Air Curtain	9	15	20	26	31	255	425	566	736	878	64	75	80	83	85	81	193	310	485	535
A85012	300mm Air Curtain	19	30	41	52	63	538	849	1161	1472	1784	63	74	78	83	81	92	293	483	652	655
A85018	450mm Air Curtain	28	44	61	77	94	793	1246	1727	2180	2662	66	78	81	82	86	90	298	502	661	668
A85024	600mm Air Curtain	37	59	81	103	125	1048	1671	2294	2917	3540	64	76	82	84	90	93	301	488	674	676
A85030	750mm Air Curtain	47	74	102	129	156	1331	2095	2888	3653	4417	70	81	85	87	88	99	308	488	675	678
A85036	900mm Air Curtain	56	89	122	155	188	1586	2520	3455	4389	5324	66	78	86	89	88	95	306	491	680	685
300mm pipe with 11 x 2mm DIA holes (25mm spacing)		20	33	46	58	70	566	934	1303	1642	1982	73	79	81	85	87	79	166	375	470	569

* Sound level taken 1 meter from source
Measured at factory setting



All you need, from the best in the business

Meech is also a leading provider of:

- **Industrial Static Control Systems** – Eliminating unwanted static or creating a controlled static charge in industrial processes can increase productivity, reduce waste and enhance quality.
- **Web Cleaning Systems** – Typically used within the printing and packaging industries to remove contamination, improve print quality and increase productivity.
- **JetStream Air Knife Systems** – Energy efficient air knife systems that are used for contamination and surface moisture removal.
- **ESD** – High sensitivity static control for electronic cleanroom environments to prevent ESD damage and reduce failure rates.

Meech International

2 Network Point
Range Road, Witney
OX29 0YN, UK

Tel: +44 (0)1993 706700
Fax: +44 (0)1993 776977
email: sales@meech.com

Meech Static Eliminators (Shanghai) Co. Ltd

7G, 7F, LP Tower
#25 Xiangfeng Road
201103 Shanghai
China

Tel: +86 400 820 0102
Fax: +86 21 6405 7736
email: china@meech.com

© Meech Static Eliminators Ltd 2025

Meech Static Eliminators USA Inc

1298 Centerview Circle
Akron, OH 44321
USA

Tel: +1 330 564 2000 / 1 800 232 4210
Fax: +1 330 564 2005
email: info@meech.com

Meech Shavotech

29/2, Kharadi
Off Pune-Nagar Road
On Old Kharadi Mundhwa Road
Pune : 411014 , Maharashtra
India

Tel: +91 (0)703 093 8211 / +91 (0)741 000 4817
Fax: +91 (080) 28395963
email: india@meech.com

Meech Elektrostatik SA

Kaiserbaracke 166
B-4780 St.Vith
Belgium

Tel.: +49 (0)6555 3733 399
+32 (0)80 670 204
Fax: +32 (0)80 862 821
email: mesa@meech.com

Meech International (Singapore) Pte. Ltd.

7 Temasek Boulevard
12 - 07 Suntec Tower One
Singapore
Singapore
038987

Tel: +65 65918859
email: singapore@meech.com

Meech CE

Gábor László utca 2
Budapest 1041
Hungary

Tel: +36 1 7977039
+36 30 2803334
email: ce@meech.com

www.meech.com

